



Scan for more information

**PA-39**  

---

**User Manual**

# Table of Contents

Specifications/Dimensions.....	3
Included Components.....	4
Basic Wiring Setup.....	5
Single/Dual Operation.....	6
Dual Actuator Sequence Programming.....	8
Dip Switch Function.....	10
Mounting.....	11

Have any queries? Our expert engineers are here to help!



[sales@progressiveautomations.com](mailto:sales@progressiveautomations.com)



1-800-676-6123



[progressiveautomations.com](http://progressiveautomations.com)



# Specifications

<b>Control Ability</b>	2 Actuators with Potentiometers In Sync/Sequence/Individual Control
<b>Input Voltage</b>	12-24 VDC
<b>Output Voltage</b>	12-24 VDC
<b>Current</b>	15A (7.5A Per Channel)
<b>Kit Includes</b>	1 Control Box, 1 Hand Remote, 1 Wire Harness, Mounting Hardware
<b>Special Feature</b>	Remote comes with 3 presets
<b>Remote Functions</b>	Up, Down, Pause (Momentary)
<b>Size (L x H x W)</b>	4.9" x 1.3" x 3.7"
<b>Weight</b>	0.8 lbs
<b>Warranty</b>	18 Months

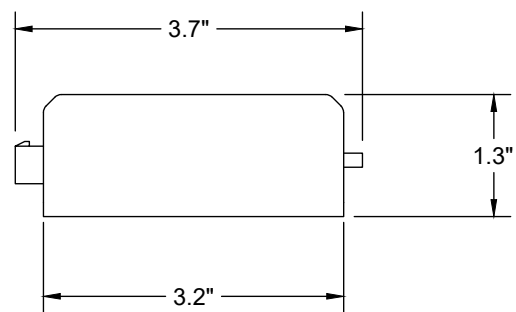
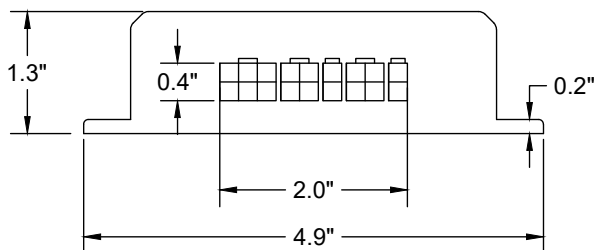
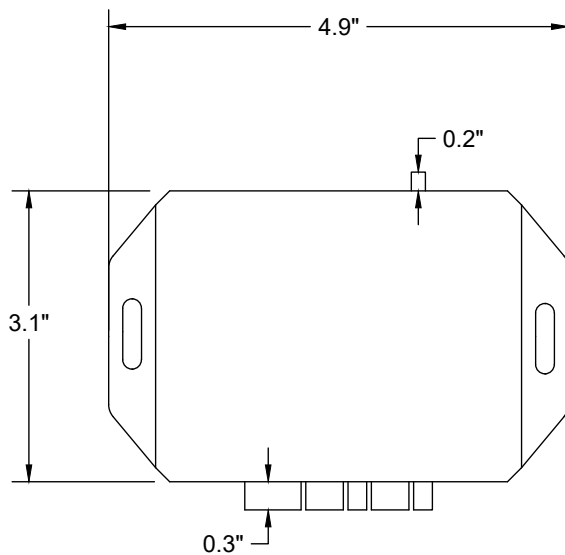
# Dimensions

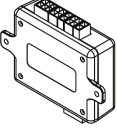
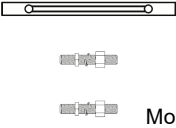
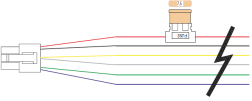
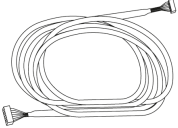

# Included Components

Part	Qty.	Part	Qty.
 Display	1	 Double-Sided Tape	1
 Central Control Unit	1	 Mounting Hardware	1
 Wire Harness	1	 Display Harness	1

## OVERVIEW

---

The dual linear actuator controller is a programmable, 3 preset controller that allows individual or sequence linear actuator function.

# Wiring Diagram

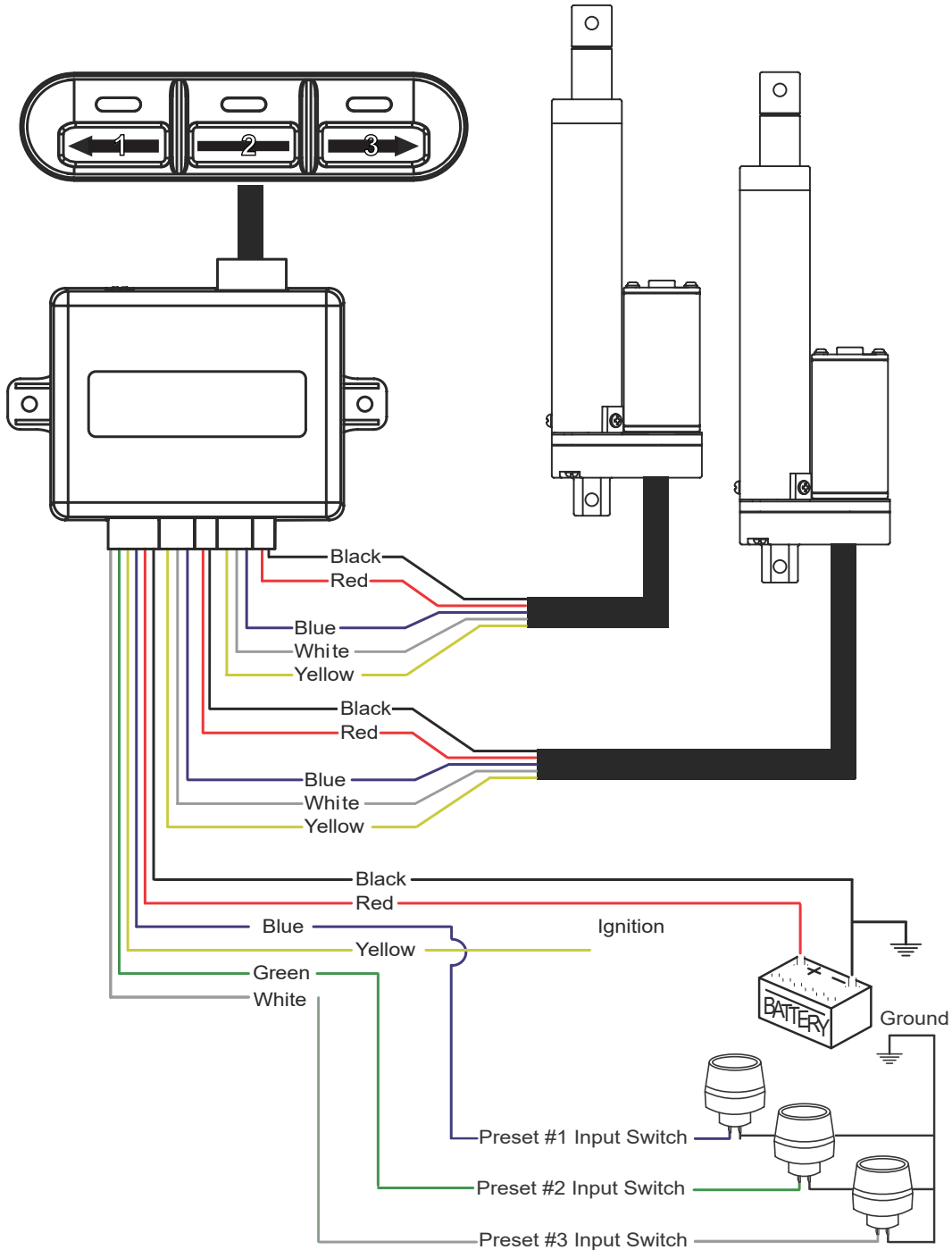

Power Pin



Actuator Potentiometer Pin

# Single/Dual Operation

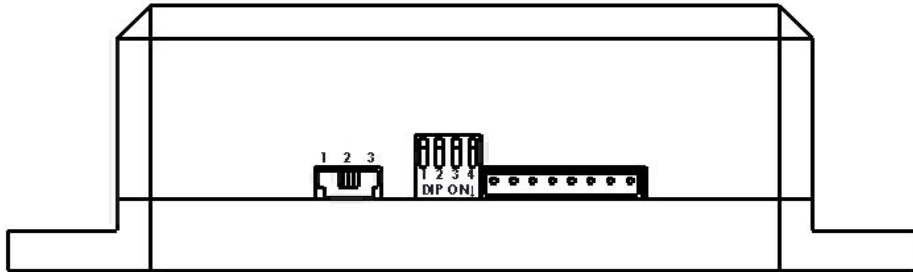

## DIP SWITCH POSITIONS

---

### Position 1: Actuator 1

### Position 2: Both Actuators

To program both actuators, they must both be retracted. First, set the switch to position 1 and retract the first actuator. Then set the switch to position 3 and retract the second actuator.

Presets can be saved at any point desired along the stroke. They do not have to be set in order.

### Position 3: Actuator 2

### Moving the Actuators

Individual or sequence linear actuator function.



# Single/Dual Operation

Press buttons 1 and 2 together to make the actuator retract.

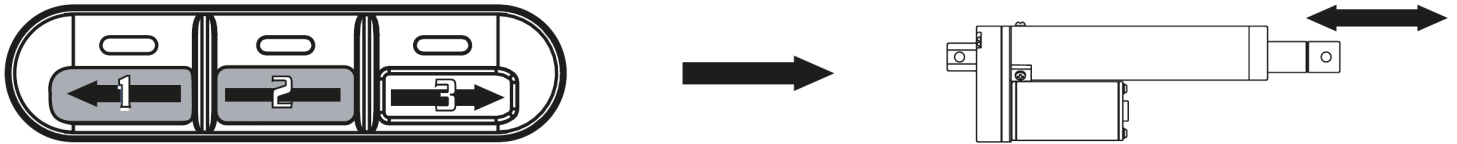

## PROGRAMMING PRESETS

---

There are three presets available on this model. Use the following instructions for programming.

1. Extend the actuator(s) to the point you'd like to have the first preset.

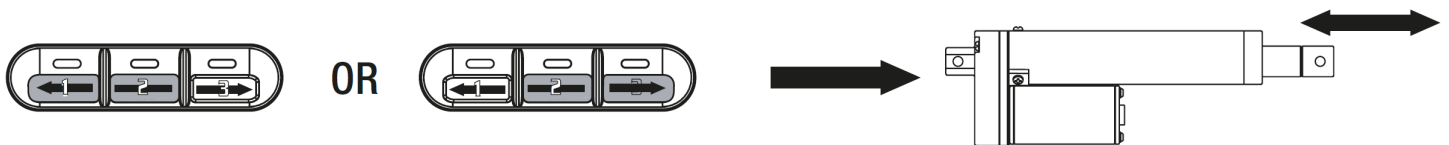

2. Press and hold button 1 for 5 seconds. The LED will flash to indicate the preset has been saved.



Repeat this process for preset 2 and 3, using the respective buttons. For setting presets on actuator 2, slide the dip switch to position 2.

# Dual Actuator Sequence Programming

## STEP 1: DIP SWITCH POSITIONING

---

Ensure 4-Bit DIP Switch Configuration:

Set Switch 3 in ON position (0100 = SW 4, SW 3, SW 2, SW 1). All other switches must be in OFF position.

## STEP 2: ACTUATOR 1 POSITION PROGRAMMING (MUST BE FOLLOWED IN ORDER)

---

### Actuator 1 Start Position:

1. Slide the 3-way position horizontal slider switch to the utmost LEFT (position 1) to set programming mode to ACTUATOR 1 MODE
2. Hold down buttons 2&3 at the same time to EXTEND the actuator. Hold own buttons 1&2 at the same time to RETRACT the actuator.
3. When the starting position of actuator 1 is selected HOLD DOWN BUTTON 1 for five (5) seconds until red light above the button flashes. Once the button flashes, actuator 1 starting position is saved.

### Actuator 1 End Position:

1. Ensure the 3-way position in the utmost LEFT position
2. Hold down buttons 2&3 at the same time to EXTEND the actuator. Hold own buttons 1&2 at the same time to RETRACT the actuator.
3. When the ending position of actuator 1 is selected HOLD DOWN BUTTON 3 for five (5) seconds until red light above the button flashes. Once the button flashes, actuator 1 ending position is saved.

## STEP 3: ACTUATOR 2 POSITION PROGRAMMING (MUST BE FOLLOWED IN ORDER)

---

### Actuator 2 Start Position:

1. Slide the 3-way position horizontal slider switch to the utmost RIGHT (position 3) to set programming mode to ACTUATOR 2 MODE
2. Hold down buttons 2&3 at the same time to EXTEND the actuator. Hold own buttons 1&2 at the same time to RETRACT the actuator.
3. When the starting position of actuator 1 is selected HOLD DOWN BUTTON 1 for five (5) seconds until red light above the button flashes. Once the button flashes, actuator 2 starting position is saved.

### Actuator 2 End Position:

1. Ensure the 3-way position in the utmost LEFT position
2. Hold down buttons 2&3 at the same time to EXTEND the actuator. Hold own buttons 1&2 at the same time to RETRACT the actuator.
3. When the ending position of actuator 1 is selected HOLD DOWN BUTTON 3 for five (5) seconds until red light above the button flashes. Once the button flashes, actuator 2 ending position is saved.



# Dual Actuator Sequence Programming

## STEP 4: SEQUENCE OPERATION MODE

---

After completing steps 1 through 3, set the 3-way position horizontal slider switch to the CENTER (position 2).

Your sequential programming is complete and may now be operated.

### **Operation Sequence and Information:**

Button 1: Sets actuators 1 and 2 to START position. Regardless of the individual actuator position, the actuators will return to their programmed START position.

Sequence in the following order:

1. Actuator 2 moves to START position
2. Actuator 1 moves to START position

Button 3: Sets actuators 1 and 2 to END position. Regardless of the individual actuator position, the actuators will position to their programmed END position.

Sequence in the following order:

1. Actuator 1 moves to END position
2. Actuator 2 moves to END position

Button 2: Controls the reversal of the sequence of actuator extension. For example, if actuator 1 extends before actuator 2, pressing button 2 will result in actuator 2 extending before actuator 1.

# Dip Switch Function

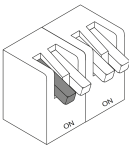
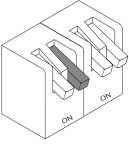
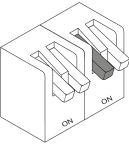
Position		Function	Action	For
#1 	On	Operates only when ignition is present.	Operates only when yellow ignition wire receives +12VDC.	For controlling items when ignition is on.
	Off	Operates only when ignition is not present.	Operates only when yellow ignition wire is not receiving +12VDC.	For making an actuator function when the power to the entire system is off.
#2 	On	Auto return to preset 1 with loss of ignition.  Auto return to preset 2 with ignition.	When +12VDC is removed from yellow ignition wire, the actuator will travel to preset 1.  When yellow ignition wire receives +12VDC, the actuator will travel to preset 2.	For projects that return to their positions when the power to the entire system is off.
	Off	No function of actuators.	When power to the system is turned off, the actuators will not move.	For projects where no actuators movement is required when power is off.
Position		Function		
#3 	On	This position is used for the dual actuator preset for 2 stage sequences.		
	Off	2 stage feature off.		

# Mounting

Press buttons 1 and 2 together to make the actuator retract.

## DOUBLE-SIDED TAPE

---

We have included double-sided tape which can be used to mount the display to any surface.

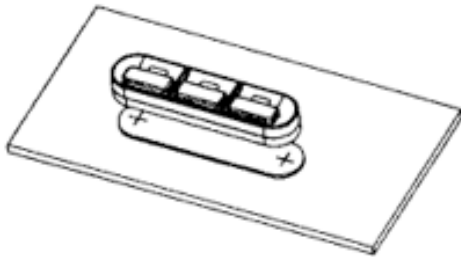

## MOUNTING BOLTS

---

The mounting bolts that have been provided are a stable and secure mounting option. Use the double sided tape or the support bracket for marking and drilling holes.

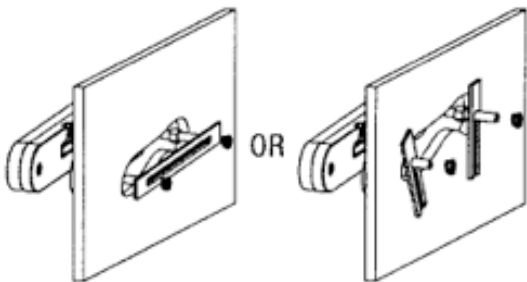

## REVERSIBLE REAR DISPLAY PANEL

---

The rear display is designed so that the harness can exit either the top or the bottom of the display remote.

Use the following instructions to reverse the display:

1. Gently separate the two halves of the display. Use a fingernail or other tool to snap the halves apart. They are not attached with screws.

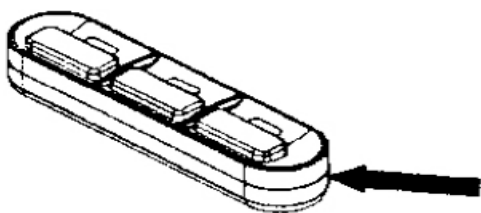

# Mounting

2. Reverse the display.

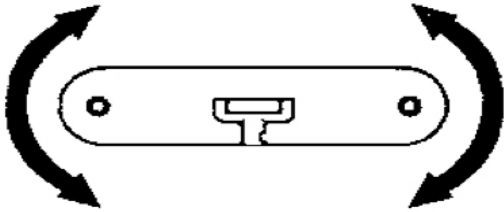

3. Snap the front and rear halves back into place.

